

# Not Quite So Mini-HotSpot V2

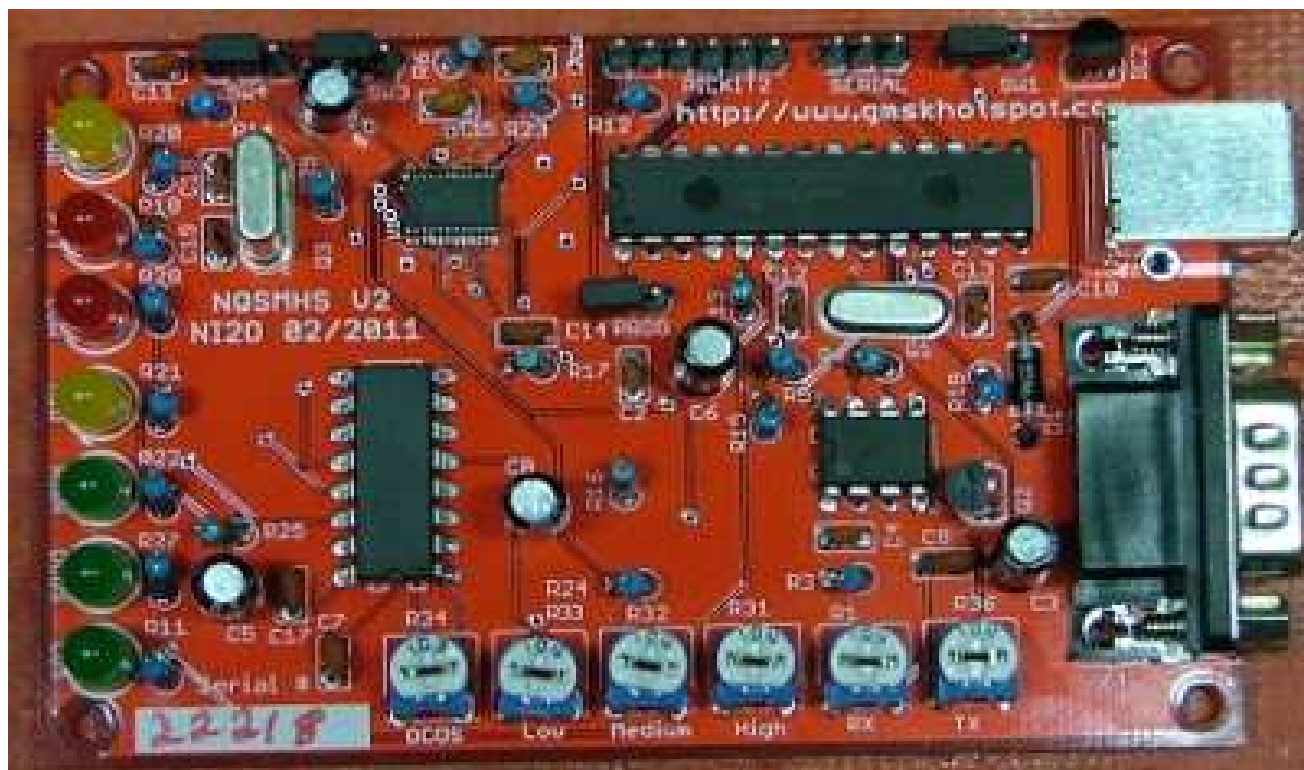

**Schematic diagram and notes for version V2**

**Mark A Phillips G7LTT/NI20**  
<http://www.gmskhotspot.com>

**ENIcommunications Corp**  
**70 Brookside Road**  
**Randolph**  
**NJ 07869**  
**973 828 1625**

**Copyright 2011 ENIcommunications Corp. All Rights Reserved**

## Installation Notes

Thank you for purchasing the G7LTT/NI20 GMSK Not Quite So Mini-HotSpot V2. For updates to this document visit <http://www.gmskhotspot.com/nqsmhs-v2.html>

Your NQSMHS-V2 comes complete with a PIC micro controller which has been pre-programmed with the DUTCH\*Star PICboot boot loader for USB. This along with the supplied license key will allow you to install and run the DUTCH\*Star HSA firmware which can be found at <http://www.dutch-star.eu>.

You may also choose alternative firmware. Running such firmware will require you to reprogram the supplied PIC. Your board has facilities for a PICKit2 style ICSP.

Before attaching your NQSMHS-V2 to your PC for programming please ensure that the jumper settings for the installation of the DUTCH\*Star HSA firmware into the board are as follows (sockets facing right);

SW1	left	(USB powered)
PROG	installed	(force boot loader enable)
SW3	removed	(RSSI disabled)
SW4	right	(RSSI disabled)

When attached to the PC for programming the COS LED will illuminate indicating that the board is ready to be programmed. Once programmed disconnect your board and remove the PROG jumper (if installed). Re-attach the board for normal operation.

The GMSK Not Quite So Mini HotSpot V2 comes as a kit of parts for self construction so you'll need to follow the basic instructions below. This kit should take an average builder a little over an hour to complete. Your NQSMHS-V2 is supplied with an SMD CMX589A GMSK modem chip. All the other parts are regular sized components.

Unlike other kits you may have built where one would first add all the mechanical parts (connectors, jumpers etc) followed by the passive parts (resistors, capacitors etc) followed by the semiconductors (IC's, diodes, crystals etc) it has been found that the easiest way to construct the NQSMHS V2 is to take a vertical approach – build the board from the bottom up. Construction in the following manner will greatly speed up the process and also provide a stable platform onto which you'll apply your iron.

### Construction

Solder the SMD GMSK modem chip (U1) to the board.

Next comes the jumpers and headers. Take care to ensure that the pins are as straight as possible. Things can get a bit crowded around the pins later on.

Solder in all the electrolytic capacitors ensuring their correct polarity. The stripe on the body of the capacitor is inserted into the round hole on the board.

At this point you should see that the board will be stable when standing up-side-down on your bench. This will make for a much easier soldering platform as we progress.

Install the 2 crystals, voltage regulator, transistor and diode. Again, be sure to follow the outlines on the board as to how to orientate the parts.

Now its time to install and solder the USB and DB9 connectors. Make sure that they are pressed flush to the board.

Populate the remaining capacitors.

Install the variable resistors.

Install the LED's.

Install the resistors.

**DO NOT INSTALL/SOLDER THE REMAINING CHIPS!**

Double check your work looking for solder bridges and correct component placement etc.

### **Testing**

Now we need to check a few voltage levels as well as configure the jumpers for V4 operation. Check the circuit diagram for the correct jumper positions. The settings at the beginning of this document are correct for V4 operation.

Connect the board to your PC via a USB cable. The first thing you should note is that there is no smoke rising from your board and that the PWR LED is lit. If the row of LED's is lit up then you haven't correctly soldered the SMD GMSK chip. Triple check your work with a magnifying glass.

When you are satisfied with your initial power-up test break out your voltage meter and check for +5V at the following locations;

U1 pins 3/4/15/17/24  
IC6 pin 20  
IC5 pin 8  
IC1 pins 15/16

Assuming the above voltages are correct unplug the board and install the remaining chips.

### **Initial setup**

Reconnect your board to the USB cable. You should now note that both the PWR and COS LED's are lit. The COS LED indicates that the PIC is ready to receive the DUTCH\*Star firmware. Refer to the DUTCH\*Star instructions for details on this operation.

If you choose to use other firmware you'll have to reprogram the supplied PIC by either connecting your PICKit2 programmer to the 6 pin header on the board or remove the PIC to program externally.

With the board sockets facing to the right, turn all the variable resistors EXCEPT RX and TX to the 10 o'clock position. These settings are approximate. The only "pot" that does any real work is the DCOS which sets the level at which the digital "squelch" opens thus activating the COS. The remaining 3 set the levels at which the LED bar graph operates.

Set the TX and RX resistors to the middle of their range. This should be sufficient for most all TRX's on the market today. Adjustment of these parts will be by trial and error. If you have access to some proper test gear you should adjust TX for 1.5KHz deviation and adjust RX for 0.8vP-P at pin 10 of U1 upon receipt of a GMSK signal.

### **Operation**

Operation of your NQSMHS-V2 will vary according to the firmware you are running, chosen software application and a few other things. Please refer to their relevant documents for instructions.

### **Jumpers**

Set the jumpers as follows for either V4 (RSSI disabled) or V5 (RSSI enabled) operation;

V4	SW3	off	SW4	right
V5	SW3	on	SW4	left



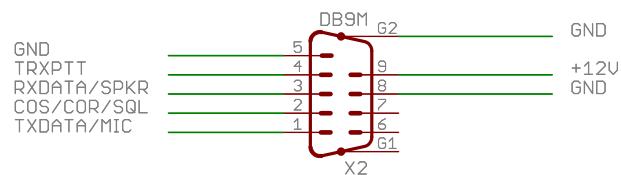
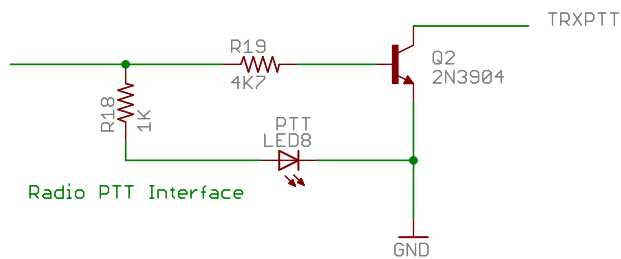
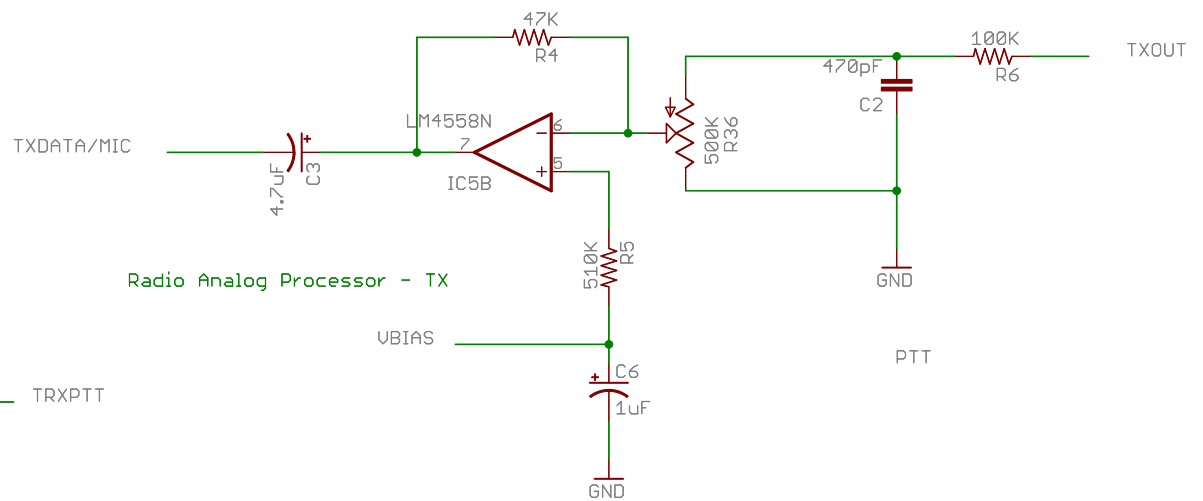
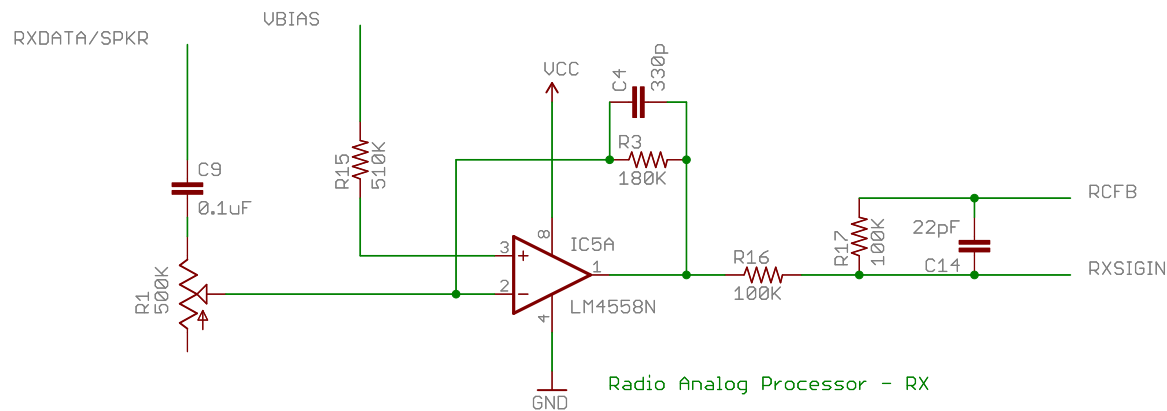

# Analog Front End

TITLE: NQSMHS-U2\_final

Document Number:

REV:  
A

Date: 5/11/11 8:51 AM

Sheet: 2/4

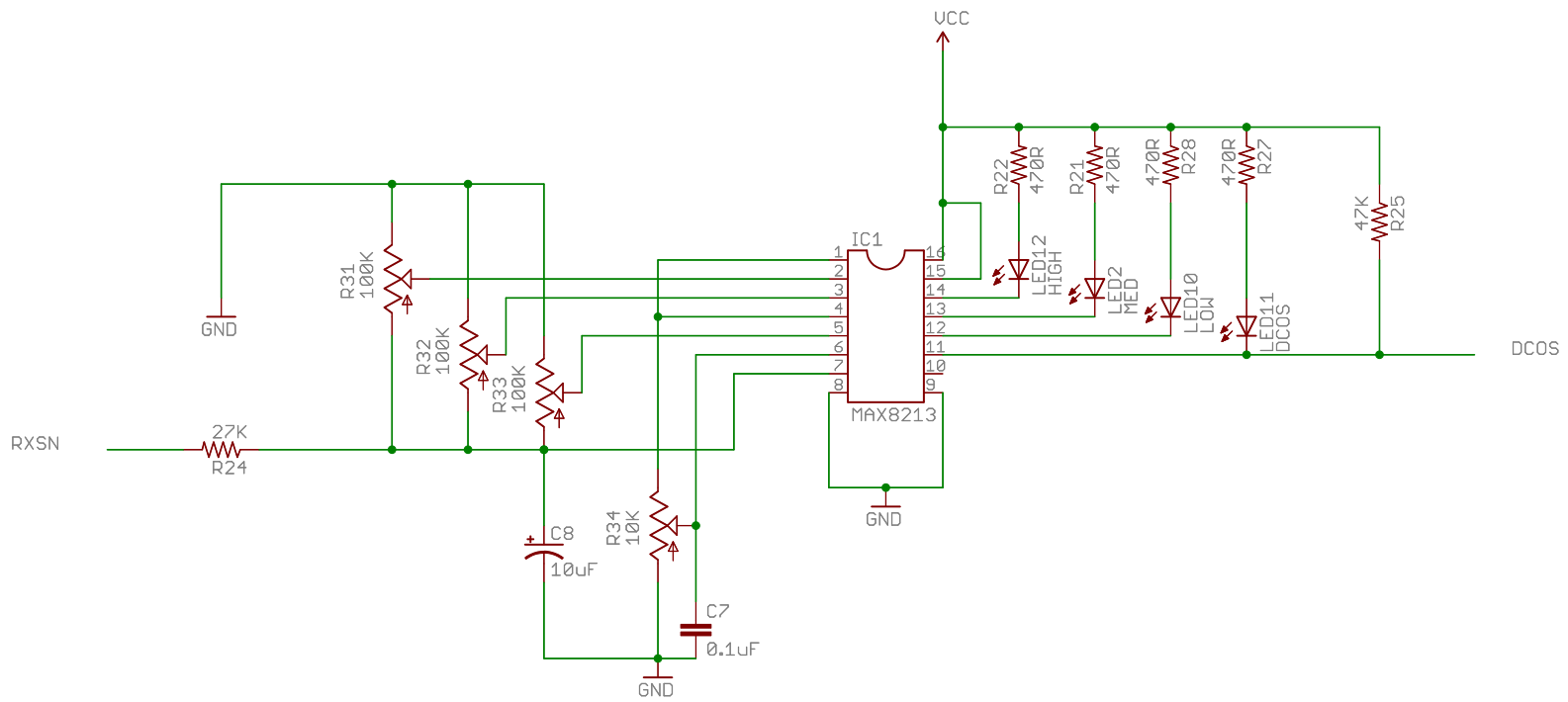

# Digital COS

TITLE: NQSMHS-U2\_final

Document Number:

REV:  
A

Date: 5/11/11 8:51 AM

Sheet: 3/4

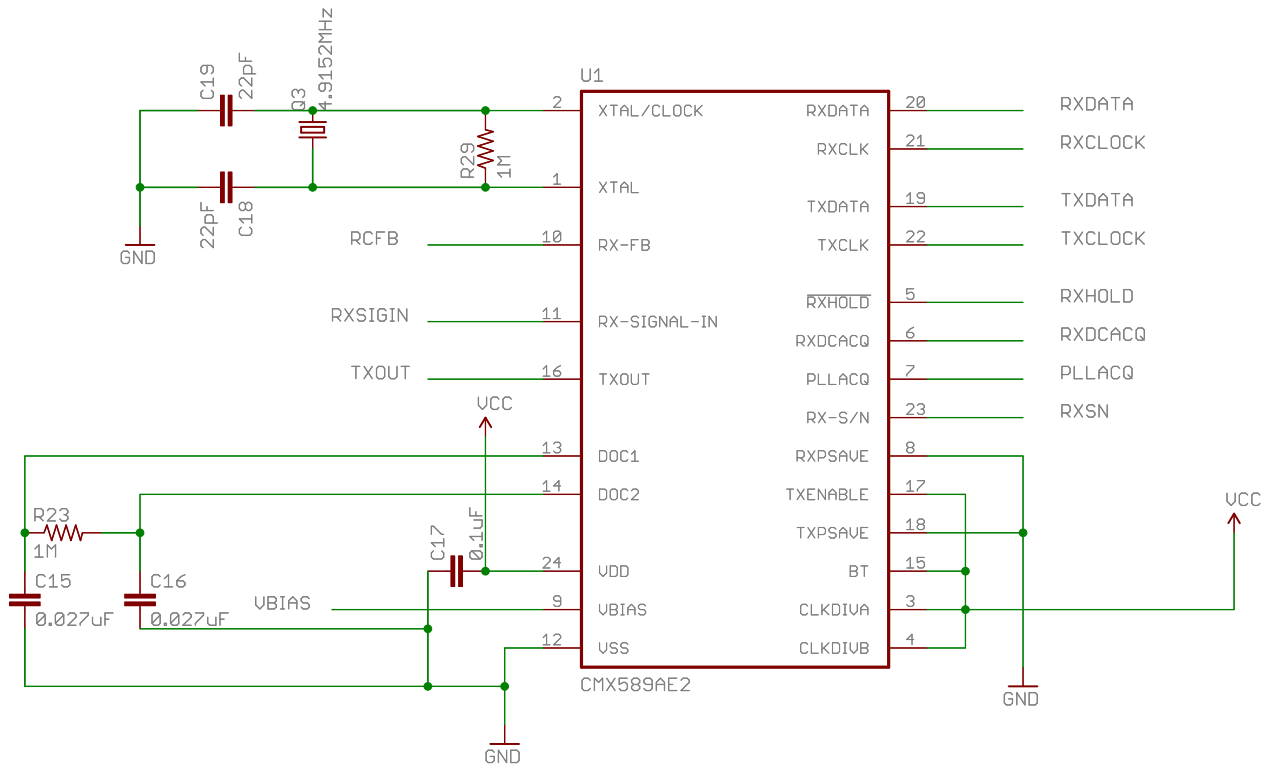

## GMSK Modem

TITLE: NQSMHS-U2\_final

Document Number:

REV:  
A

Date: 5/11/11 8:51 AM

Sheet: 4/4

<http://www.gmskhotspot.com>

NQSMHS V2  
NI20 02/2011

IC2

SW1

SERIAL

PICKIT2

IC6

SW3

SW4

C1

R14

R20

C11

PWR

PTT

LOW

MED

HIGH

DCOS

COS

R29

R18

R28

R21

R22

R27

R11

C5

C17

R25

C7

R34

R33

R32

R31

R1

R36

C3

C9

R5

R4

R19

R17

C2

C6

R16

C8

R24

R23

R3

R1

R3

R1

R36

C3

C9

R5

R4

R19

R17

C2

C6

R16

C8

R24

R23

R3

R1

R3

R1

R36

C3

C9

R5

R4

R19

R17

C2

C6

R16

C8

R24

R23

R3

R1

R3

R1

R36

C3

C9

R5

R4

R19

R17

C2

C6

R16

C8

R24

R23

R3

R1

R3

R1

R36

C3

C9

R5

R4

R19

R17

C2

C6

R16

C8

R24

R23

R3

R1

R3

R1

R36

C3

C9

R5

R4

R19

R17

C2

C6

R16

C8

R24

R23

R3

R1

R3

R1

R36

C3

C9

R5

R4

R19

R17

C2

C6

R16

C8

R24

R23

R3

R1

R3

R1

R36

C3

C9

R5

R4

R19

R17

C2

C6

R16

C8

R24

R23

R3

R1

R3

R1

R36

C3

C9

R5

R4

R19

R17

C2

C6

R16

C8

R24

R23

R3

R1

R3

R1

R36

C3

C9

R5

R4

R19

R17

C2

C6

R16

C8

R24

R23

R3

R1

R3

R1

R36

C3

C9

R5

R4

R19

R17

C2

C6

R16

C8

R24

R23

R3

R1

R3

R1

R36

C3

C9

R5

R4

R19

R17

C2

C6

R16

C8

R24

R23

R3

R1

R3

R1

R36

C3

C9

R5

R4

R19

R17

C2

C6

R16

C8

R24

R23

R3

R1

R3

R1

R36

C3

C9

R5

R4

R19

R17

C2

C6

R16

C8

R24

R23

R3

R1

R3

R1

R36

C3

C9

R5

R4

R19

R17

C2

C6

R16

C8

R24

R23

R3

R1

R3

R1

R36

C3

C9

R5

R4

R19

R17

C2

C6

R16

C8

R24

R23

R3

R1

R3

R1

R36

C3

C9

R5

R4

R19

R17

C2

C6

R16

C8

R24

R23

R3

R1

R3

R1

R36

C3

C9

R5

R4

R19

R17

C2

C6

R16

C8

R24

R23

R3

R1

Sheet1

Part	Value	Marking
C1	10uF	10uF
C2	470pF	471
C3	4.7uF	4.7uF
C4	330p	331
C5	47uF	47uF
C6	1uF	1uF
C7	0.1uF	104
C8	10uF	10uF
C9	0.1uF	104
C10	0.1uF	104
C11	0.1uF	104
C12	22pF	22
C13	22pF	22
C14	22pF	22
C15	0.027uF	273
C16	0.027uF	273
C17	0.1uF	104
C18	22pF	22
C19	22pF	22
D1	1N4001	1N4001
IC1	MAX8213	MAX8213
IC2	78L05	78L05
IC5	LM4558N	4558
IC6	PIC18F2550	PIC18F2550
J1	USBPTH	
LED1	COS	Green
LED2	MED	Yellow
LED3	PWR	Yellow
LED8	PTT	Red
LED10	LOW	Red
LED11	DCOS	Green
LED12	HIGH	Green
PICKIT2	PICKIT2	
PROG	Program	
Q1	24MHz	24MHz
Q2	2N3904	2N3904
Q3	4.9152MHz	4.9152MHz
R1	500K	504 or 104
R3	180K	brown/grey/black/orange/brown
R4	47K	yellow/violet/black/red/brown
R5	510K	green/brown/black/orange/brown
R6	100K	brown/black/black/orange/brown
R11	1K	brown/black/black/brown/brown
R12	10K	brown/black/black/red/brown
R13	47K	yellow/violet/black/red/brown
R14	27K	red/violet/black/red/brown
R15	510K	green/brown/black/orange/brown

Sheet1

R16	100K	brown/black/black/orange/brown
R17	100K	brown/black/black/orange/brown
R18	1K	brown/black/black/brown/brown
R19	4K7	yellow/violet/black/brown/brown
R20	1K	brown/black/black/brown/brown
R21	470R	yellow/violet/black/black/brown
R22	470R	yellow/violet/black/black/brown
R23	1M	brown/black/black/yellow/brown
R24	27K	red/violet/black/red/brown
R25	47K	yellow/violet/black/red/brown
R27	470R	yellow/violet/black/black/brown
R28	470R	yellow/violet/black/black/brown
R29	1M	brown/black/black/yellow/brown
R31	100K	104
R32	100K	104
R33	100K	104
R34	10K	103
R36	500K	504 or 104
SERIAL	SERIAL	
SW1	SW1	
SW3	SW3	
SW4	SW4	
U1	CMX589AE2	SMD Part
X2	DB9M	

## **Not Quite So Mini-HotSpot V2 Addendum Page**

- 1) Some users report very low transmit data levels emitting from the board. A quick fix for this is to cut the right leg of the TX pot.
- 2) Some users have reported that the PTT remains keyed long after the data has gone. This appears to be RF feedback holding the PTT transistor open. Place a 100pF (101) cap between the base of Q2 and ground.

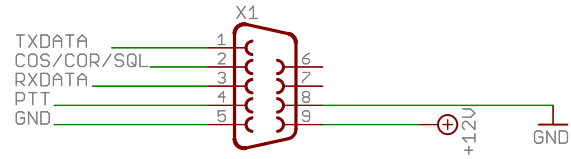
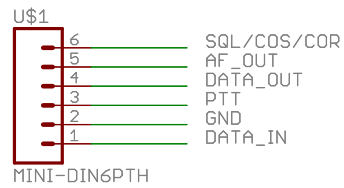
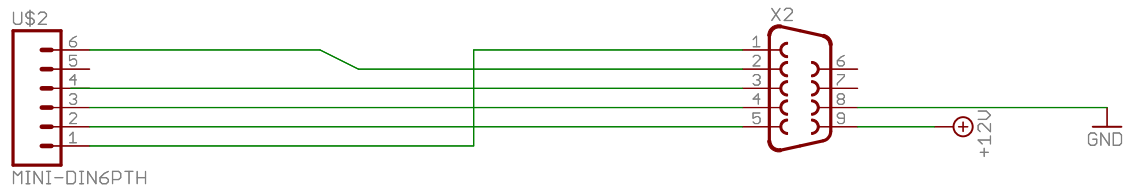

## NQSMHS to 6 pin Mini DIN

TITLE: 6pin-minidin\_to\_MHS

Document Number:

REV:

Date: 3/15/11 11:04 PM

Sheet: 1/1

# 6-Pin MiniDIN Packet Connector

The 6-Pin MiniDIN “PS/2” jack is a standard used by all the Japanese ham manufacturers.

This jack is variously called "data", "packet", "auxiliary", etc, but actually there are no data connections on this connector. This **IS NOT** a serial data or RTTY direct FSK port; only various forms of RX and TX **audio** are present. The connector provides **receive audio** output at about 100-300mV, **transmit audio** input at about the same level, transmit **PTT** keying, receiver **squelch status** (COR), and **ground**/common.

The normal RX audio line, which is live on both FM and SSB in multimode transceivers, is sometimes labeled "1200 baud packet" but it is just standard receiver audio (de-emphasized on FM) similar to what comes out the radio's speaker. However, it is at a fixed level unaffected by the volume control. The jack is suitable for any voice-frequency band application such as SSTV, Echolink/IRLP interfaces, PSK31, RTTY, 1200 baud packet TNCs, APRS trackers, DTMF and paging encoders/decoders/selective calls, etc.

The audio levels into and out-of this connector are similar to RCA-jack home audio “line level” connections on amplifiers, tuners, CD & DVD players, etc. They are also a nearly perfect match for the levels on 3.5mm computer sound card “Line Out” and “Line In” (not Mic input!) jacks. No attenuator pads or voltage dividers are required.

On radios with FM, the 6th pin is a DC-coupled connection directly to the receiver FM discriminator. The NON-demphasized wide-band audio at this point is normally used by 9600 baud or higher packet modes.

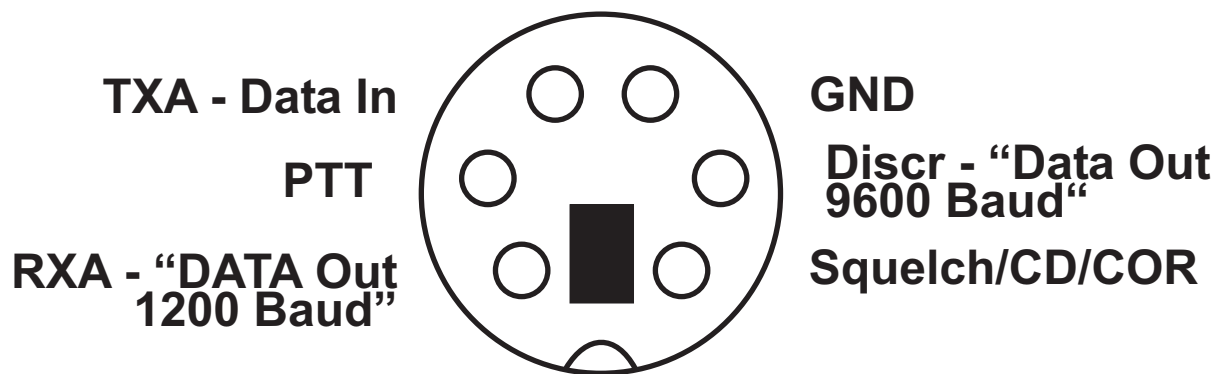

Viewed Looking Into FEMALE (Panel) Socket  
(Soldering End of MALE Plug)

This is the same jack as the standard computer PS/2 mouse/keyboard connector. A PS/2 mouse/keyboard extension cord, available at most computer stores, is an excellent source of a cable for this jack. Note that cables salvaged from dead keyboards or mice often only have 4 of the 6 conductors present.

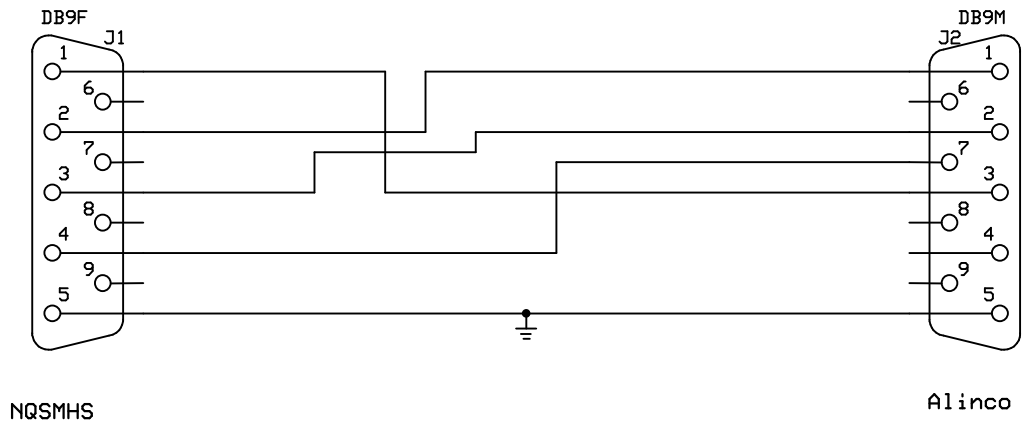

DB9F

- 1 = White
- 2 = Red
- 3 = Green
- 4 = Black
- 5 = Braid

DB9M

- 1 = Red
- 2 = Green
- 3 = White
- 5 = Braid
- 7 = Black

NQSMHS

- 1 = TX audio to radio (to Data In)
- 2 = COS/COR/SQL
- 3 = RX audio from radio (from Data Out)
- 4 = PTT
- 5 = GND
- 9 = +12VDC

Alinco

- 1 = COS/COR/SQL
- 2 = 9600bd out (Discriminator)
- 3 = 9600bd in (Modulator)
- 4 = 1200bd out (Speaker)
- 5 = GND
- 6 = NC
- 7 = PTT
- 8 = +5VDC
- 9 = 1200bd in (Mic)

ENIcommunications Corp

CAB Alinco

Mark Phillips

Rev 1.0

10/12/2010

Page 1 of 1

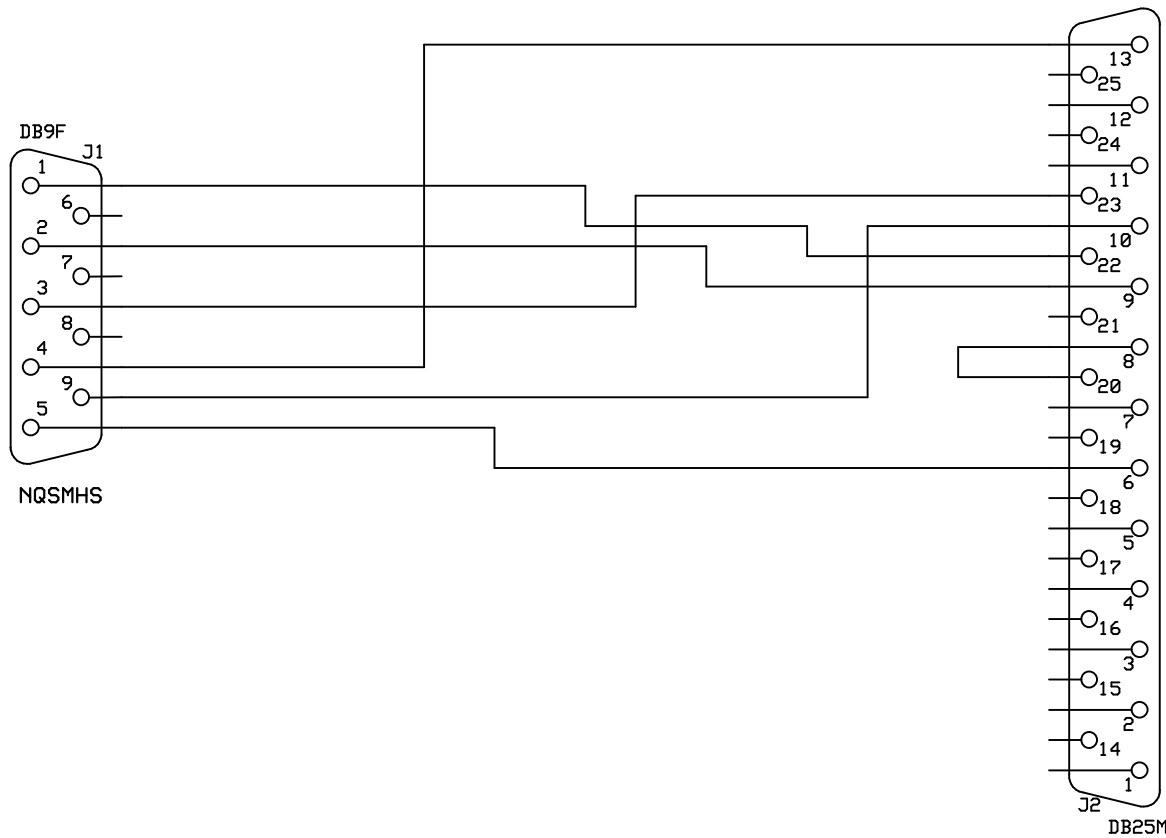

- DB9F**
- 1 = White
  - 2 = Red
  - 3 = Green
  - 4 = Black
  - 5 = Braid
  - 9 = Purple

- DB25M**
- 6 = Braid
  - 8 = Bridged to 20
  - 9 = Red
  - 10 = Purple
  - 13 = Black
  - 20 = Bridged to 8
  - 22 = White
  - 23 = Green

**NQSMHS**

- 1 = TX audio to radio (to Data In)
- 2 = COS/COR/SQL
- 3 = RX audio from radio (from Data Out)
- 4 = PTT
- 5 = GND
- 9 = +12VDC

**DeskTrac**

- 1 = GND
- 2 = NC
- 3 = B+ <13.8VDC @ 750mA>
- 4 = PCC TEL
- 5 = MIC TEL
- 6 = GND
- 7 = DRXA TEL
- 8 = GND
- 9 = CHAN MON <COS/COR/SQL>
- 10 = B+ <13.8VDC @ 750mA>
- 11 = EXT ALARM
- 12 = PL CHAN MON
- 13 = PTT
- 14 = LINE PTT
- 15 = DRXA EXT LCL
- 16 = TXA EXT LCL
- 17 = TX CTCSS
- 18 = MONITOR
- 19 = PTT EXT LCL
- 20 = RPTR DIS
- 21 = TX PL INH
- 22 = TXA <DATA IN>
- 23 = RXA <DATA OUT>
- 24 = PTT PAGER
- 25 = MIC PAGER

**ENIcommunications Corp**

**CAB DeskTrac**

Mark Phillips

Rev 1.0  
10/26/2010

Page 1 of 1

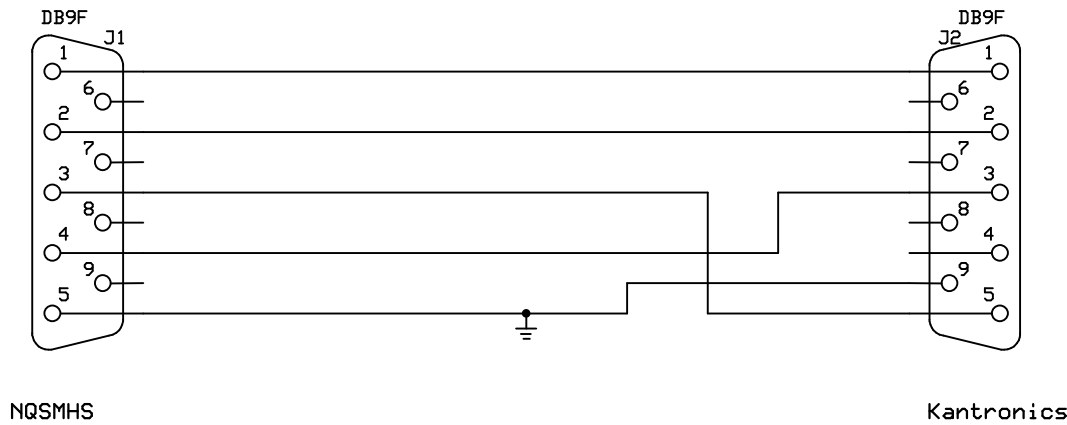

DB9F

- 1 = White
- 2 = Red
- 3 = Green
- 4 = Black
- 5 = Braid

DB9F

- 1 = White
- 2 = Red
- 3 = Black
- 5 = Green
- 9 = Braid

NQSMHS

- 1 = TX audio to radio (to Data In)
- 2 = COS/COR/SQL
- 3 = RX audio from radio (from Data Out)
- 4 = PTT
- 5 = GND
- 9 = +12VDC

Kantronics

- 1 = Data In (Modulator)
- 2 = COS/COR/SQL
- 3 = PTT
- 4 = NC
- 5 = Data Out (Discriminator)
- 6 = GND
- 7 = NC
- 8 = Speaker Out
- 9 = GND

ENIcommunications Corp

CAB Kan

Mark Phillips

Rev 1.0  
10/12/2010

Page 1 of 1

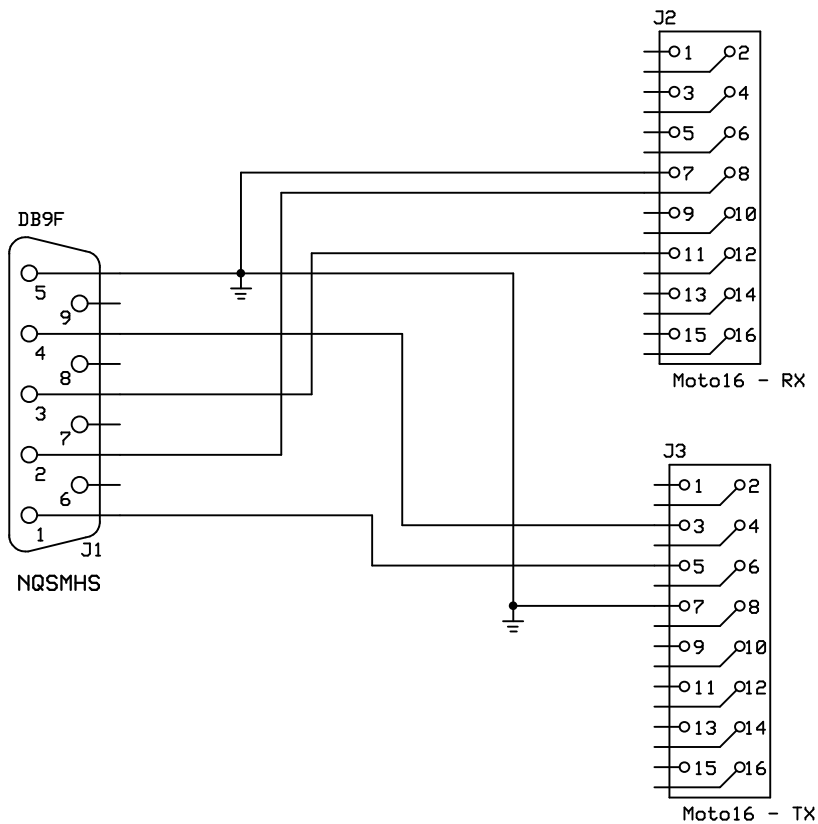

DB9F

- 1 = White
- 2 = Red
- 3 = Green
- 4 = Black
- 5 = Braid

Moto16 - RX

- 7 = Braid
- 8 = Red
- 11 = Green

Moto16 - TX

- 3 = Black
- 5 = White
- 7 = Braid

NQSMHS

- 1 = TX audio to radio (to Data In)
- 2 = COS/COR/SQL
- 3 = RX audio from radio (from Data Out)
- 4 = PTT
- 5 = GND
- 9 = +12VDC

Motorola 16 pin (Maxtrac/GM300/ETC)

- 1 = External Speaker Negative
- 2 = Mic
- 3 = PTT
- 4 = External Alarm
- 5 = Flat TX Audio (Modulator)
- 6 = NC
- 7 = GND
- 8 = COS/COR/SQL
- 9 = Emergency Alert Input
- 10 = Ignition Control Input
- 11 = Discriminator Audio Output
- 12 = NC
- 13 = Switch A+ Sense
- 14 = Remote Hook Switch Input
- 15 = Internal Speaker Positive
- 16 = External Speaker Positive

ENIcommunications Corp

CAB Moto16-RPT

Mark Phillips

Rev 1.0  
10/18/2010

Page 1 of 1

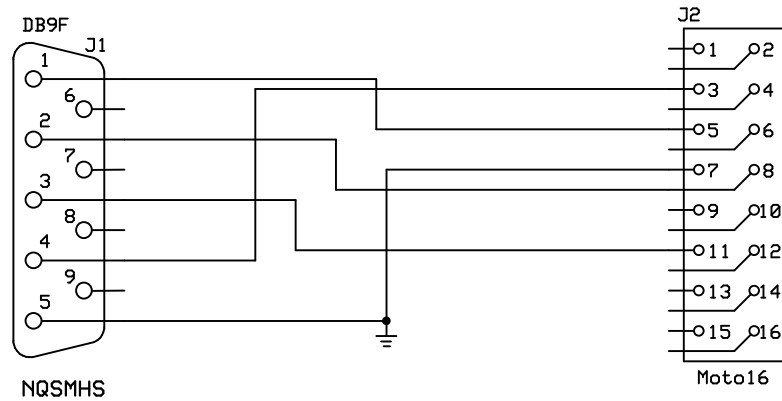

DB9F  
 1 = White  
 2 = Red  
 3 = Green  
 4 = Black  
 5 = Braid

Moto16  
 3 = Black  
 5 = White  
 7 = Braid  
 8 = Red  
 11 = Green

**NQSMHS**

- 1 = TX audio to radio (to Data In)
- 2 = COS/COR/SQL
- 3 = RX audio from radio (from Data Out)
- 4 = PTT
- 5 = GND
- 9 = +12VDC

**Motorola 16 pin (Maxtrac/GM300/ETC)**

- 1 = External Speaker Negative
- 2 = Mic
- 3 = PTT
- 4 = External Alarm
- 5 = Flat TX Audio (Modulator)
- 6 = NC
- 7 = GND
- 8 = COS/COR/SQL
- 9 = Emergency Alert Input
- 10 = Ignition Control Input
- 11 = Discriminator Audio Output
- 12 = NC
- 13 = Switch A+ Sense
- 14 = Remote Hook Switch Input
- 15 = Internal Speaker Positive
- 16 = External Speaker Positive

ENIcommunications Corp

CAB Moto16

Mark Phillips

Rev 1.0  
 10/12/2010

Page 1 of 1