

Not Quite So Mini-HotSpot

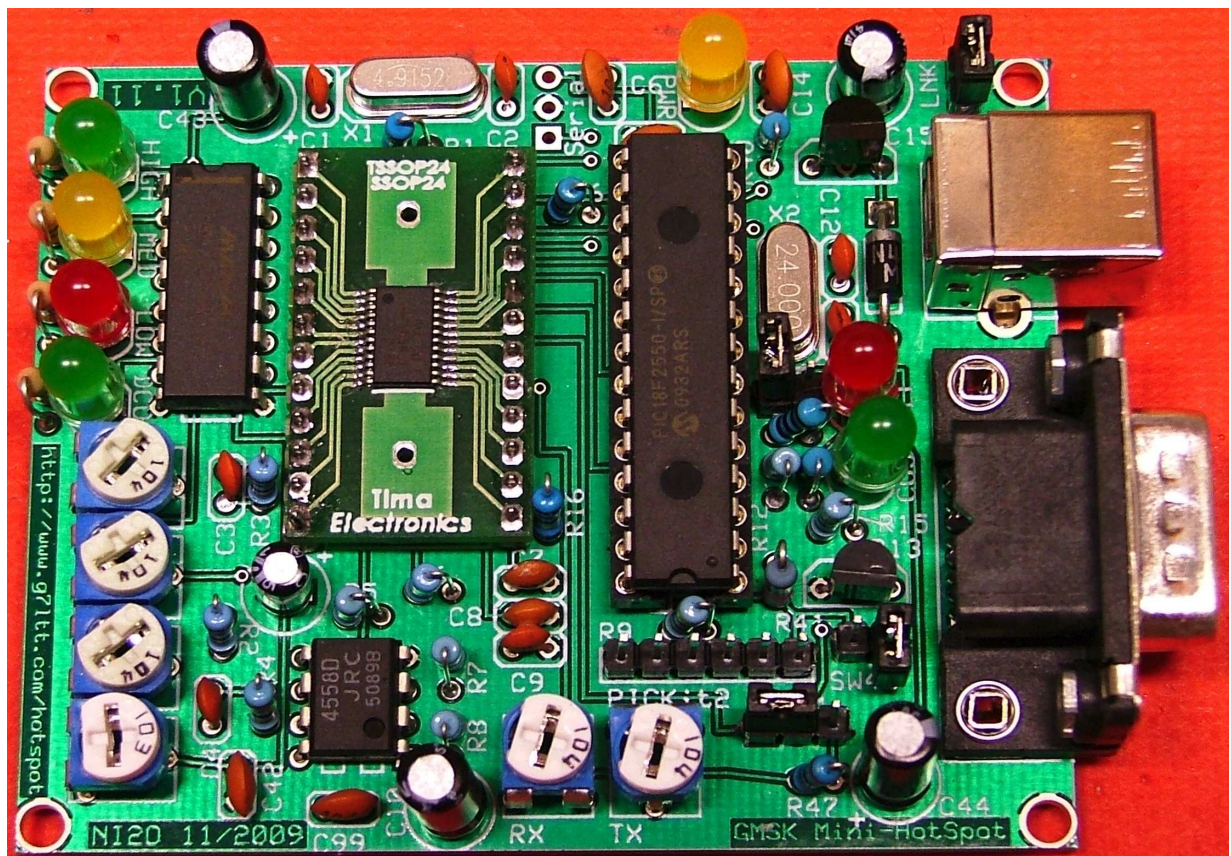

Schematic diagram and notes for version V1.14

Mark A Phillips G7LTT/NI20
<http://www.gmskhotspot.com>

Installation Notes

Thank you for purchasing the G7LTT/NI2O GMSK Not Quite So Mini-HotSot. For updates to this document please visit <http://www.gmskhotspot.com/nqsmhs.html>

Your NQSMHS comes complete with a PIC micro controller which has been pre-programmed with the DUTCH*Star PICboot boot loader for USB. This will allow you to purchase and run the DUTCH*Star HSA firmware which can be found at <http://www.dutch-star.eu>.

You may also choose alternative firmware. Running such firmware will require you to reprogram the supplied PIC. Your board has facilities for a PICKit2 style ICSP.

Before attaching your NQSMHS to your PC for programming please ensure that the jumper settings for the installation of the DUTCH*Star HSA firmware into the board are as follows (sockets facing right);

SW1	lower	(USB powered)
SW2	installed	(force boot loader enable)
SW3	removed	(RSSI disabled)
SW4	left	(RSSI disabled)

When attached to the PC for programming the COS LED will illuminate indicating that the board is ready to be programmed. Once programmed disconnect your board and remove the SW2 jumper. Re-attach the board for normal operation.

The GMSK Not Quite So Mini HotSpot comes in 2 basic forms; a kit of parts for self construction (NQSMHS-K) or a pre-built board (NQSMHS-B). If you bought a pre-built you need only to install your chosen firmware and you are ready to go.

If you bought a kit you'll need to follow the basic instructions below. This kit should take an average builder a little over an hour to complete. Your NQSMHS has the ability to utilize both PDIP and SMD CMX589A GMSK modem chips. For supply reasons you may have either the SMD or PDIP part. All the other parts are regular sized components.

Unlike other kits you may have built where one would first add all the mechanical parts (sockets, jumpers etc) followed by the passive parts (resistors, capacitors etc) followed by the semiconductors (IC's, diodes, crystals etc) it has been found that the easiest way to construct the NQSMHS is to take a vertical approach – build the board from the bottom up. Construction in the following manner will greatly speed up the construction and also provide a stable platform onto which you'll apply your iron.

Construction

Solder the SMD GMSK modem chip (U1) to the board. If yours is a PDIP version then simply install the supplied socket for the GMSK modem chip (we'll install the chip at the end of the build).

Solder the IC socket for the PIC (U2) and both the remaining IC's taking care to note their correct orientations.

Next comes the jumpers and headers. Take care to ensure that the pins are as straight as possible. Things can get a bit crowded around the pins later on.

Solder in all the electrolytic capacitors ensuring their correct polarity. The stripe on the body of the capacitor is inserted into the round hole on the board.

At this point you should see that the board will be stable when standing up-side-down on your bench. This will make for a much easier soldering platform as we progress.

Install the 2 crystals, voltage regulator, transistor and diode. Again, be sure to follow the outlines on the board as to how to orientate the parts.

Now its time to attach the sockets. Install and solder the USB and DB9 connectors.

Populate the remaining capacitors.

Install the variable resistors.

Install the LED's.

Install the resistors.

Double check your work looking for solder bridges and correct component placement etc.

Testing

Before we insert the remaining IC's into their respective sockets we need to check a few voltage levels as well as configure the jumpers for V4 operation. Check the circuit diagram for the correct jumper positions.

Connect the board to your PC via a USB cable. The first thing you should note is that there is no smoke rising from your board and that the PWR LED is lit. If the row of 4

LED's is lit up then either you have not installed your PDIP GMSK modem chip (we'll do that later) or you haven't correctly soldered the SMD GMSK chip. Triple check your work with a magnifying glass.

When you are satisfied with your initial power-up test break out your voltage meter and check for +5V at the following locations;

U1 pins 3/4/15/17/24
U2 pin 20
U3 pin 8
U4 pins 15/16

Assuming the above voltages are correct unplug the board and install the remaining chips.

Initial setup

Reconnect your board to the USB cable. You should now note that both the PWR and COS LED's are lit. The COS LED indicates that the PIC is ready to receive the DUTCH*Star firmware. Refer to the DUTCH*Star instructions for details on this operation.

If you choose to use other firmware you'll have to reprogram the supplied PIC by either connecting your PICKit2 programmer to the 6 pin header on the board or remove the PIC to program externally.

With the board sockets facing to the right, turn the uppermost variable resistor so that it faces east. Turn the one below it to face south. Turn the next one down to face south west. Finally turn the bottom one to face north east. These settings are approximate. The only "pot" that does any real work is the lowest one which sets the level at which the digital "squelch" opens thus activating the COS. The upper 3 set the levels at which the LED bar graph operates.

Set the TX and RX resistors to the middle of their range. This should be sufficient for most all TRX's on the market today. Adjustment of these parts will be by trial and error. If you have access to some proper test gear you should adjust TX for 1.5KHz deviation and adjust RX for 0.8vP-P at pin 10 of U1 upon receipt of a GMSK signal.

Operation

Operation of your NQSMHS will vary according to the firmware you are running, chosen software application and a few other things. Please refer to their relevant documents for instructions.

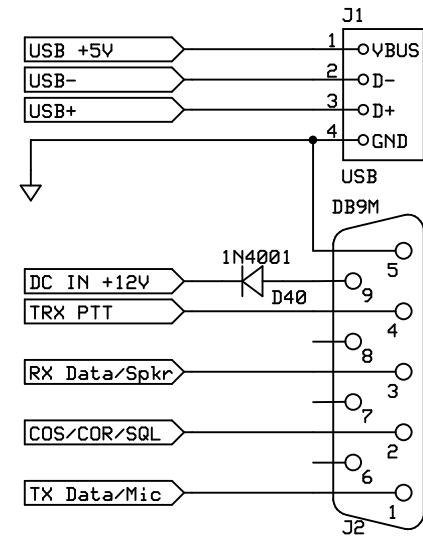
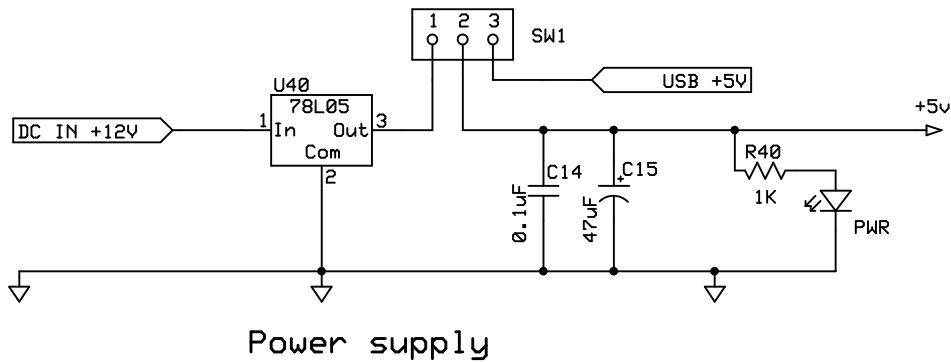

COS/COR/SQL not used in this version

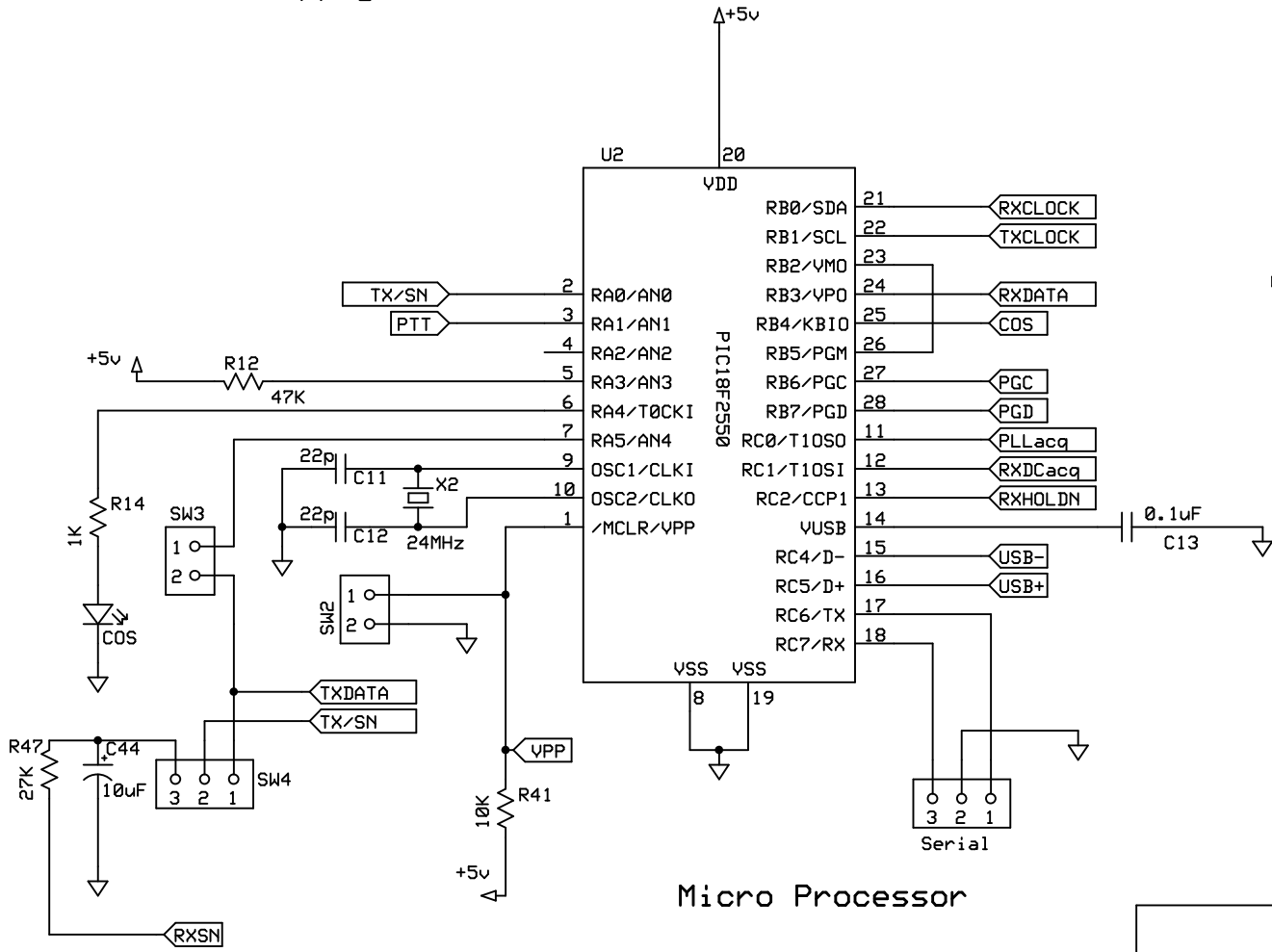
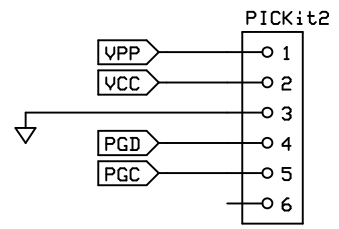

USB boot loader enable SW2 closed. Remove for normal operation
 V4.xx firmware SW4 1-2, SW3 open
 V5.xx firmware SW4 2-3, SW3 closed

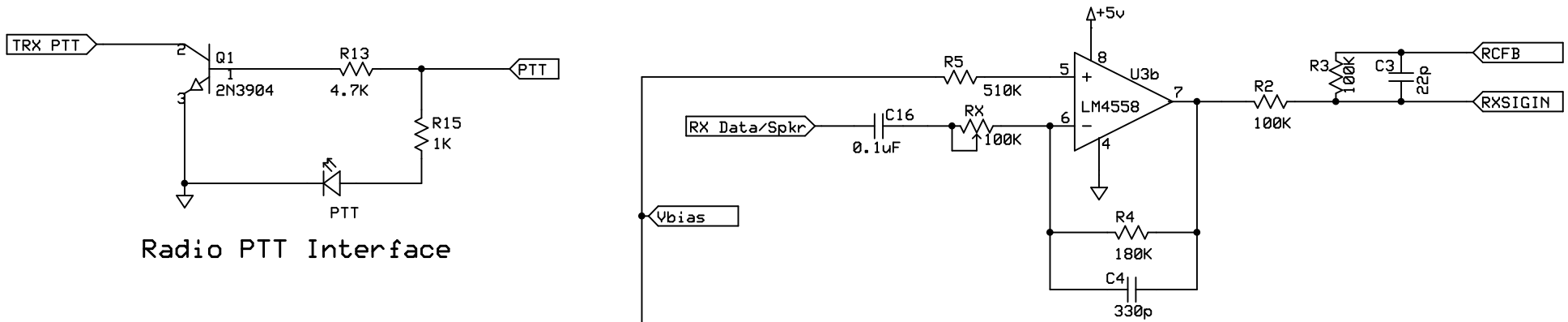

Radio PTT Interface

Radio Analog Processor

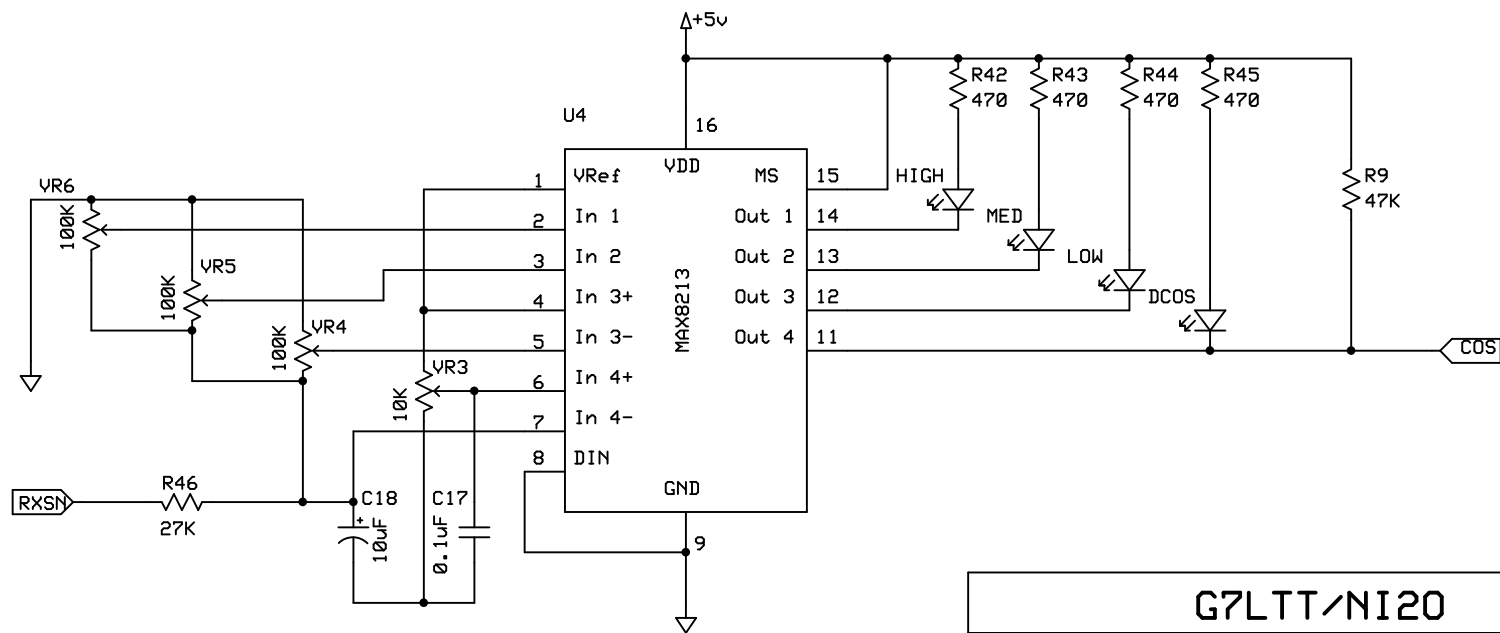
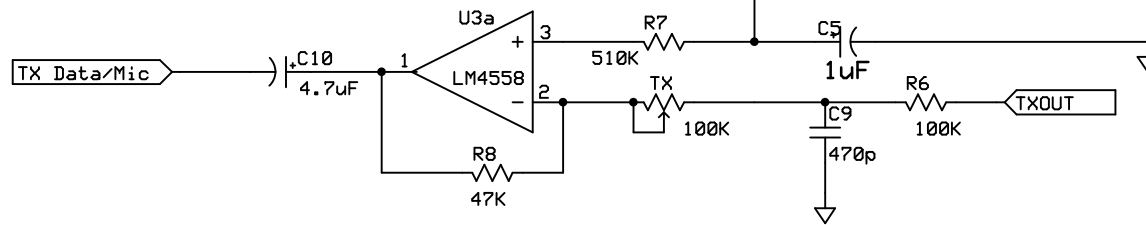

Digital COS

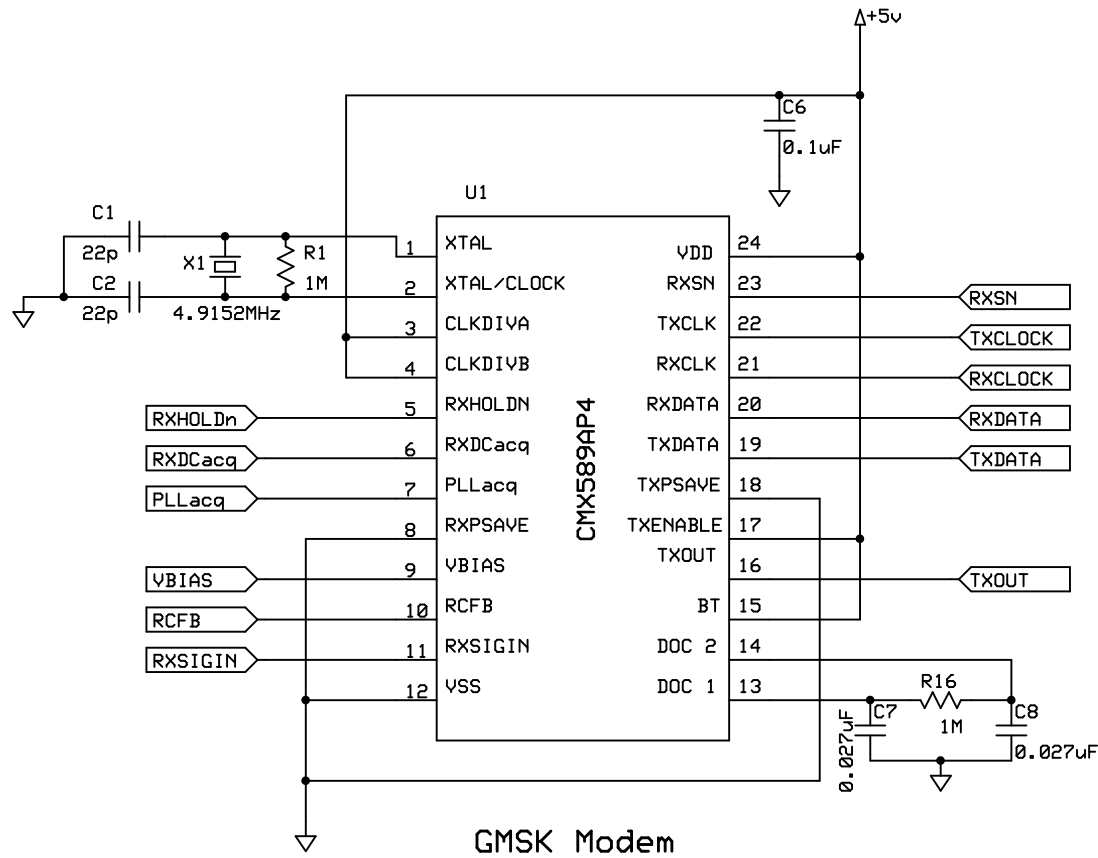

* Supported speeds = 4800bd, 9600bd, 19200bd, 38400bd assuming X2 = 4.9152MHz

* Charge pump values by data rate

speed	C7/C8	R6	C9
4800	27n	100K	470p
9600	12n	47K	470p
19200	6.8n	91K	120p
38400	3.3n	47K	120p
64000	1.8n	51K	68p
128000	860p	82K	22p

G7LTT/NI20		
Not Quite So Mini-HotSpot		
Mark Phillips	Rev 1.14	Page 3
	01/22/2010	

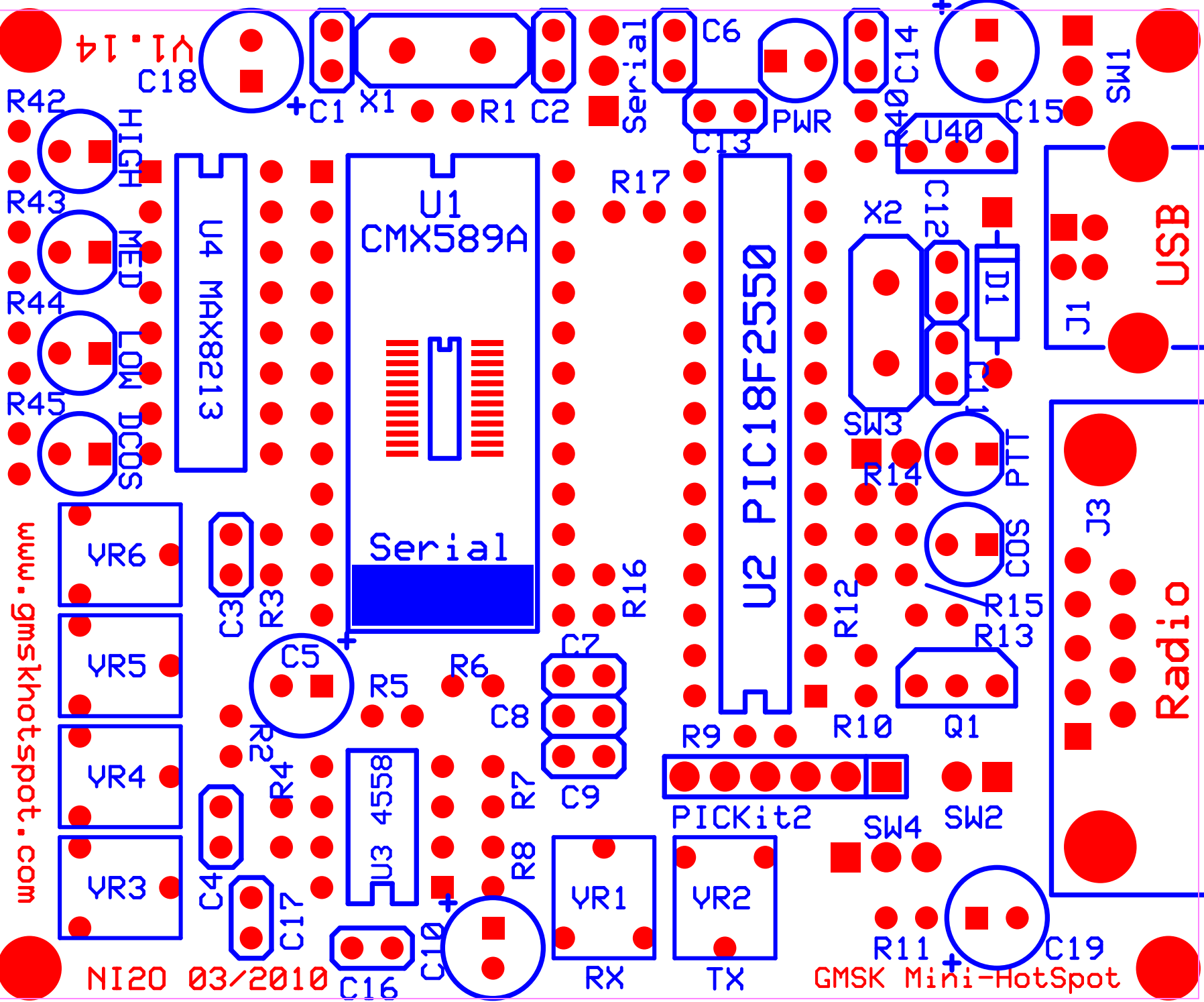

G7LTT Not Quite So Mini-HotSpot

Parts List V1.14

C1,C2, C3, C11, C12	22p	(22)
C4	330p	(331)
C5	1uF	
C6, C13, C14, C17, C16	0.1uF	(104)
C7, C8	0.027uF	(273)
C9	470p	(471)
C10	4.7uF	
C15	47uF	
C18, C19	10uF	
COS, HIGH, DCOS	Green LED	
PTT, LOW	Red LED	
PWR, MED	Amber LED	
D1	1N4001	
TX, RX, VR4, VR5, VR6	100K	(104)
VR3	10K	(103)
J1	USB "B"	
J2	DB9M	
L1, SW2, SW3	2 pin header	
PICKit2	6 pin header	
SW4, SW1, Serial	3 pin header	
R1, R16	1M	(Brown/Black/Black/Yellow/Brown)
R2,R3, R6	100K	(Brown/Black/Black/Orange/Brown)
R4	180K	(Brown/Grey/Black/Orange/Brown)
R5, R7	510K	(Green/Brown/Black/Orange/Brown)
R8, R9, R12	47K	(Yellow/Purple/Black/Red/brown)
R13	4.7K	(Yellow/Purple/Black/Brown/Brown)
R14, R15, R40	1K	(Brown/Black/Black/Brown/Brown)
R17, R11	27K	(Red/Purple/Black/Red/Brown)
R42, R43, R44, R45	470R	(Yellow/Purple/Brown)
R10	10K	(Brown/Black/Black/Red/Brown)
U1	CMX589AP4	
U2	PIC18F2550	
U40	78L05	
U3	LM4558	
U4	MAX8213	
Q1	2N3904	
X1	4.9152MHz	
X2	24MHz	
PCB1	NQSMHS V1.11 PCB	
U2-S	28 pin IC socket	
Card1	Business card with URL's etc	